

SPECIFICATION	CONNECTION	
	UNIPOLAR	BIPOLAR
VOTAGE(VOC)	3.00	4.24
AMPS/PHASE	3.00	2.12
RESISTANCE/PHASE(Ohms)@25°C	1.00±10%	2.00±10%
INDUCTANCE/PHASE(mH)@1KHz	1.60±20%	6.40±20%
HOLDING TORQUE(Nm)[lb-in]	1.35[11.95]	1.90[16.82]
STEP ANGLE(°)	1.80	
STEP ACCURACY(NON-ACCUM)	±5.00%	
ROTOR INERTIA(g-cm ²)	480.00	
WEIGHT(Kg)[lb]	1.00[2.20]	
TEMPERATURE RISE:MAX.80°C (MOTOR STANDSTILL;FOR 2PHASE ENERGIZED)		
AMBIENT TEMPERATURE -10°C~50°C[14°F~122°F]		
INSULATION RESISTANCE 100 Mohm (UNDER NORMAL TEMPERATURE AND HUMIDITY)		
INSULATION CLASS B 130°C[266°F]		
DIELECTRIC STRENGTH 500VAC FOR 1MIN.(BETWEEN THE MOTOR COILS AND THE MOTOR CASE)		
AMBIENT HUMIDITY MAX.85%(NO CONDENSATION)		

STEP	A	B	\bar{A}	\bar{B}	O(\bar{O})	CW
1	+	+			+	↓
2		+	+		+	
3			+	+	+	
4	+			+	+	
1	+	+			+	

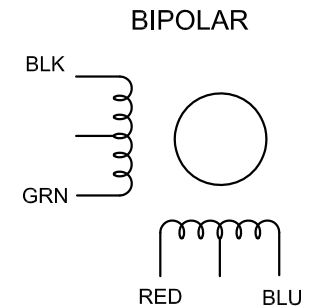
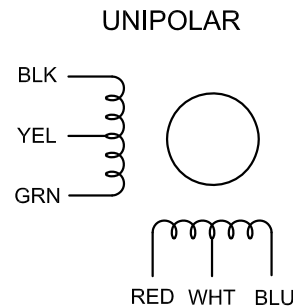

SKYSMotor

APVD		
CHKD		
1:1.5	DRN	
SCALE	SIGNATURE	DATE

STEPPER MOTOR

23HS30-3006D