

SPECIFICATION	CONNECTION	UNIPOLAR	BIPOLAR (SERIAL)	BIPOLAR (PARALLEL)
VOTAGE(VOC)		3.20	4.52	2.26
AMPS/PHASE		4.00	2.83	5.66
RESISTANCE/PHASE(Ohms)@25°C		0.80±10%	1.60±10%	0.40±10%
INDUCTANCE/PHASE(mH)@1KHz		1.80±20%	7.20±20%	1.80±20%
HOLDING TORQUE(Nm)[lb-in]		2.00[17.70]	2.83[25.05]	2.83[25.05]
STEP ANGLE(°)		1.80		
STEP ACCURACY(NON-ACCUM)		±5.00%		
ROTOR INERTIA(g-cm ²)		530.00		
WEIGHT(Kg)[lb]		1.13[2.49]		
TEMPERATURE RISE:MAX.80°C (MOTOR STANDSTILL;FOR 2PHASE ENERGIZED)				
AMBIENT TEMPERATURE -10°C~50°C[14°F~122°F]				
INSULATION RESISTANCE 100 Mohm (UNDER NORMAL TEMPERATURE AND HUMIDITY)				
INSULATION CLASS B 130°C[266°F]				
DIELECTRIC STRENGTH 500VAC FOR 1MIN.(BETWEEN THE MOTOR COILS AND THE MOTOR CASE)				
AMBIENT HUMIDITY MAX.85%(NO CONDENSATION)				

UNIPOLAR

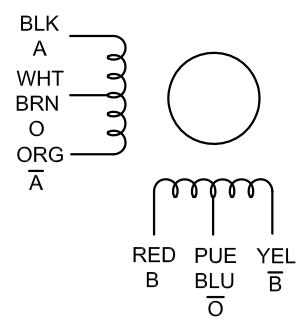

BIPOLAR SERIES

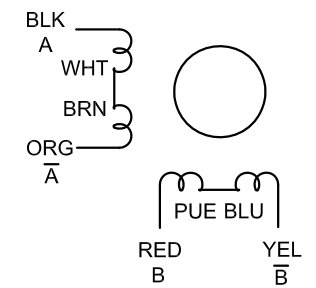

BIPOLAR PARALLEL

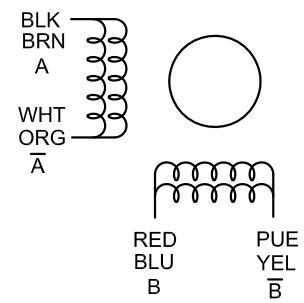

APVD		
CHKD		
1:1.5	DRN	
SCALE	SIGNATURE	DATE

STEPPER MOTOR

23HS33-4008D