

END COVER COLOR: BLACK

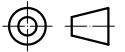
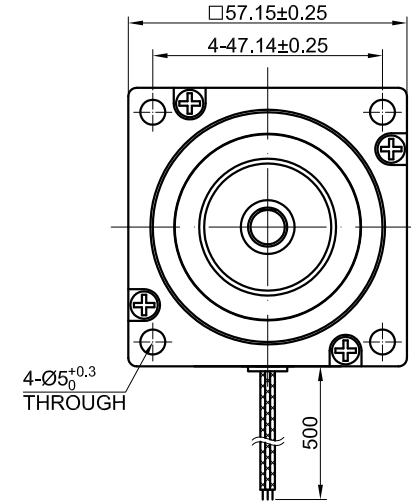
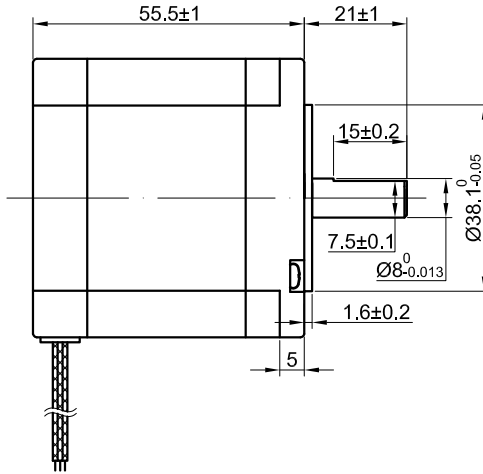
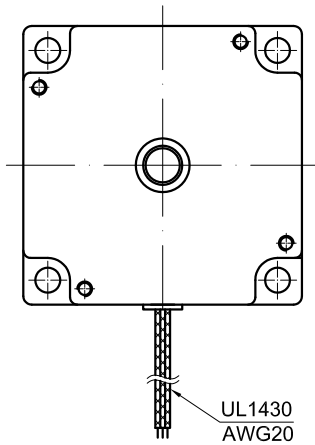

SPECIFICATION	VALUE
AMPS/PHASE	5.50
RESISTANCE/PHASE(Ohms)@20°C	0.45±10%
INDUCTANCE/PHASE(mH)@1KHz	0.98±20%
HOLDING TORQUE(Nm)[lb-in]	1.00 [8.86]
STEP ANGLE(°)	1.2±0.06
MAXIMUM RADIAL RUNOUT(mm)@LOAD 450g	0.025
MAXIMUM AXIAL RUNOUT(mm)@LOAD 920g	0.075
ROTOR INERTIA(g-cm ²)	280
WEIGHT(Kg)[lb]	—
TEMPERATURE RISE:MAX.80°C	
OPERATION AMBIENT TEMPERATURE 0°C~50°C[32°F~122°F]	
INSULATION RESISTANCE 100 Mohm (UNDER NORMAL TEMPERATURE AND HUMIDITY)	
INSULATION CLASS B 130°C[266°F]	
DIELECTRIC STRENGTH 500VAC FOR 1MIN.(BETWEEN THE MOTOR COILS AND THE MOTOR CASE)	

TYPE OF CONNECTION (EXTERN)		MOTOR
PIN NO	PHASE	LEADS
1	V	RED
2	W	BLU
3	U	GRN

FULL STEP 3 PHASE-Ex. ,
WHEN FACING MOUNTING END (X)

STEP	U	V	W	CCW	CW
1	+	-	-	↓ ↑	↑ ↓
2	-	+	-		
3	-	-	+		
4	+	-	-		

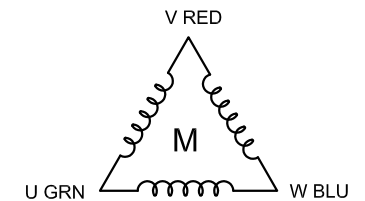

SKYSMotor

	APVD		7.12.2019
	CHKD		
1:1.5	DRN		
SCALE	SIGNATURE		DATE

STEPPER MOTOR

23HT22-5503S