

END COVER COLOR: BLACK

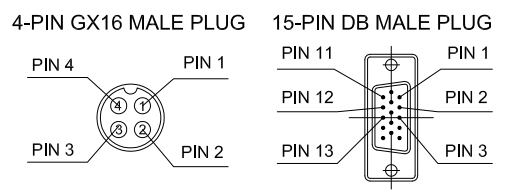
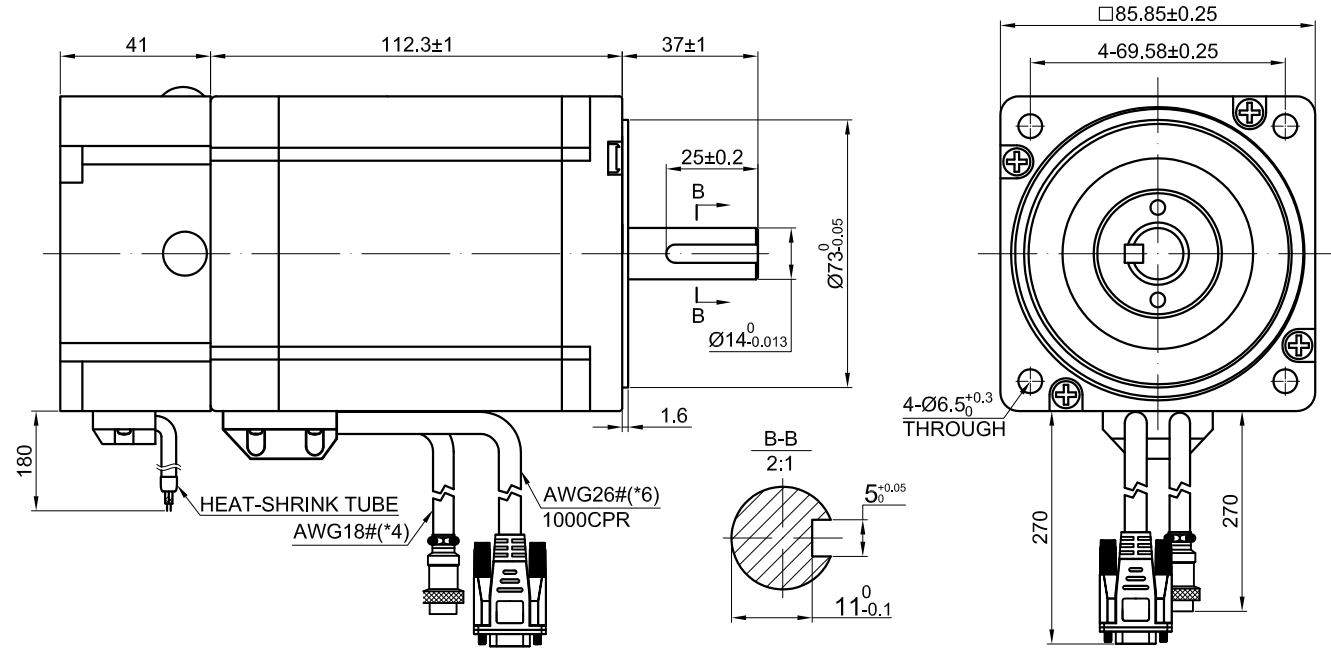
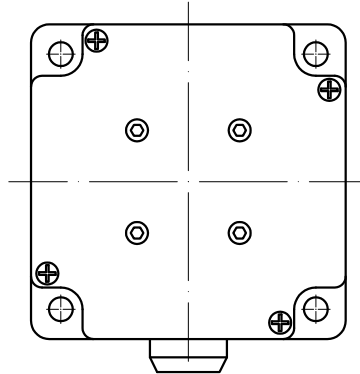

| SPECIFICATION                       | CONNECTION | BIPOLAR      |
|-------------------------------------|------------|--------------|
| AMPS/PHASE                          |            | 6.00         |
| RESISTANCE/PHASE(Ohms)@20°C         |            | 0.54±10%     |
| INDUCTANCE/PHASE(mH)@1KHz           |            | 5.00±20%     |
| HOLDING TORQUE(Nm)[lb-in]           |            | 8.50 [75.29] |
| STEP ANGLE(°)                       |            | 1.8±0.09     |
| MAXIMUM RADIAL RUNOUT(mm)@LOAD 450g |            | 0.025        |
| MAXIMUM AXIAL RUNOUT(mm)@LOAD 920g  |            | 0.075        |
| ROTOR INERTIA(g-cm²)                |            | 3600         |
| WEIGHT(Kg)[lb]                      |            | —            |

| TEMPERATURE RISE:MAX.80°C ( MOTOR STANDSTILL;FOR 2PHASE ENERGIZED )              |
|--|
| OPERATION AMBIENT TEMPERATURE 0°C~50°C[ 32°F~122°F]                              |
| INSULATION RESISTANCE 100 Mohm (UNDER NORMAL TEMPERATURE AND HUMIDITY)           |
| INSULATION CLASS B 130°C[266°F]  |
| DIELECTRIC STRENGTH 500VAC FOR 1MIN.(BETWEEN THE MOTOR COILS AND THE MOTOR CASE) |

| TYPE OF CONNECTION (EXTERN) |         | MOTOR |         |
|-----------------------------|---------|-------|---------|
| PIN NO                      | BIPOLAR | LEADS | WINDING |
| 1                           | A —     | WHT   | A       |
| 2                           | A\ —    | GRN   | A\      |
| 3                           | B —     | BLU   | B       |
| 4                           | B\ —    | BLK   | B\      |

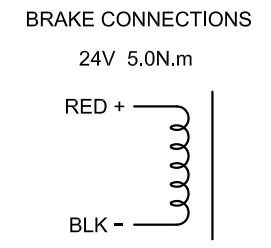

FULL STEP 2 PHASE-Ex. ,  
WHEN FACING MOUNTING END (X)

| STEP | A | B | A\ | B\ | CCW | CW |
|------|---|---|----|----|-----|----|
| 1    | + | + | -  | -  | ↓   | ↑  |
| 2    | - | + | +  | -  |     |    |
| 3    | - | - | +  | +  |     |    |
| 4    | + | - | -  | +  |     |    |

| 15-PIN DB MALE PLUG | 1   | 2   | 3   | 11  | 12  | 13  |
|---------------------|-----|-----|-----|-----|-----|-----|
| LEAD COLOR          | BLK | RED | WHT | YEL | GRN | BLU |
| DESCRIPTION         | EA+ | VCC | GND | EB+ | EB- | EA- |



|       |           |           |
|-------|-----------|-----------|
| APVD  |           | 7.12.2019 |
| CHKD  |           |           |
| 1:2   | DRN       |           |
| SCALE | SIGNATURE | DATE      |

STEPPER MOTOR

34E1KBK50-85