

SPECIFICATION	VALUE
NO. of PHASES	3
NO. of POLES	8
RATED VOLTAGE(V)	24
RATED CURRENT(A)	3.4±10%
RATED POWER(W)	52.5
RATED SPEED(RPM)	4000±10%
RATED TORQUE(mN.m)	125
NO LOAD CURRENT(A)	0.7
NO LOAD SPEED(RPM)	6500
SENSOR	HALL SENSOR
INSULATION CLASS	CLASS B
INSULATION RESISTANCE	100MΩ MIN @ 500VDC
DIELECTRIC STRENGTH TEST	500VAC for 1 MINUTE
BEARING TYPE	NMB BALL BEARING, C3

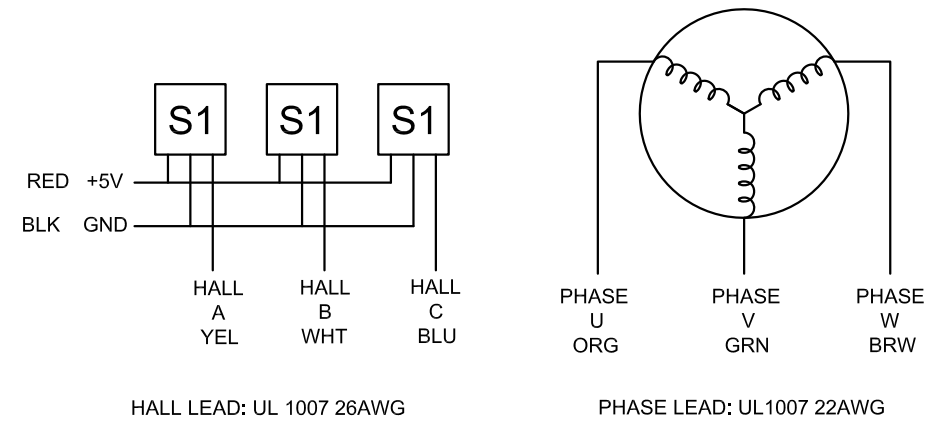

SKYSMotor

APVD		
CHKD		
1.5:1	DRN	
SCALE	SIGNATURE	DATE

BRUSHLESS DC MOTOR

42BLS60-24-01