

SKYSMotor

User Manual

DM542T(V4.0)

2-Phase Digital Stepper Drive



Revision 4.0

Record of Revisions

Revision	Date	Description of Release
1.0	Dec, 2016	Initial Release
4.0	Oct., 2020	Add 5V/24V logical voltage selector, alarm outputs

Table of Contents

1. Features.....	1
2. Specifications.....	1
2.1 Electrical Specifications.....	1
2.2 Environment.....	1
2.3 Mechanical Specifications.....	2
2.4 Elimination of Heat.....	2
3. Connection Pin Assignments and LED Indication.....	2
3.1 P1 - Control Connector.....	3
3.2 P2 - Fault and Brake Output Connector.....	3
3.3 P3 - Motor and Power Supply Connector.....	3
3.5 LED Light Indication.....	3
4. Control Signal and Output Signal.....	4
4.1 Control Signal Connection.....	4
4.2 Fault Output Connection.....	4
5. Motor Connection.....	4
6. Power Supply Selection.....	5
6.1 Power Supply Sharing.....	5
6.2 Selecting Supply Voltage.....	5
7. DIP Switch Configurations.....	5
7.1 Microstep Resolution Configurations.....	5
7.2 Output Current Configurations.....	6
7.2.1 Dynamic Current Configurations.....	6
7.2.2 Idle Current Configuration.....	7
7.3 Automatic Motor Matching & Self Configuration.....	7
8. Wiring Notes.....	7
9. Typical Connection.....	7
10. Sequence Chart of Control Signals.....	8
11. Protection Functions.....	8
12. Troubleshooting.....	9

1. Features

- Step & direction (PUL/DIR) control
- Input voltage 20-50VDC (recommended 24-48VDC)
- 200 KHz max pulse input frequency
- 16 microstep resolutions of 200-25,600 via DIP switches
- 8 output current settings of 1.0-4.5A via DIP Switches
- Idle current reduction to 50% or 90% selection via SW4
- Auto-tuning to match wide-range NEMA 11, 17, 23 and 24 stepper motors
- Anti-Resonance for optimal torque, extra smooth motion, low motor heating and noise
- Soft-start with no “jump” when powered on
- Optically isolated inputs with 5V or 24V
- Fault output
- Over-voltage and over-current protections

2. Specifications

2.1 Electrical Specifications

Parameters	DM542T(V4.0)			
	Min	Typical	Max	Unit
Output Current	1.0 (0.7 RMS)	-	4.5 (3.2 RMS)	A
Supply Voltage	18	24 - 48	50	VDC
Logic signal current	7	10	16	mA
Pulse input frequency	0	-	200	kHz
Minimal Pulse Width	2.5	-	-	μS
Minimal Direction Setup	5.0	-	-	μS
Isolation resistance	500			MΩ

2.2 Environment

Cooling	Natural Cooling or Forced cooling	
Operating Environment	Environment	Avoid dust, oil fog and corrosive gases
	Humidity	40%RH — 90%RH
	Operating Temperature	0°C — 40°C (32°F - 109°F)
	Vibration	10-50Hz / 0.15mm
Storage Temperature	-20°C — 65°C (-4°F - 149°F)	
Weight	Approx. 230g (0.51 lbs)	

2.3 Mechanical Specifications

(unit: mm [1inch=25.4mm])

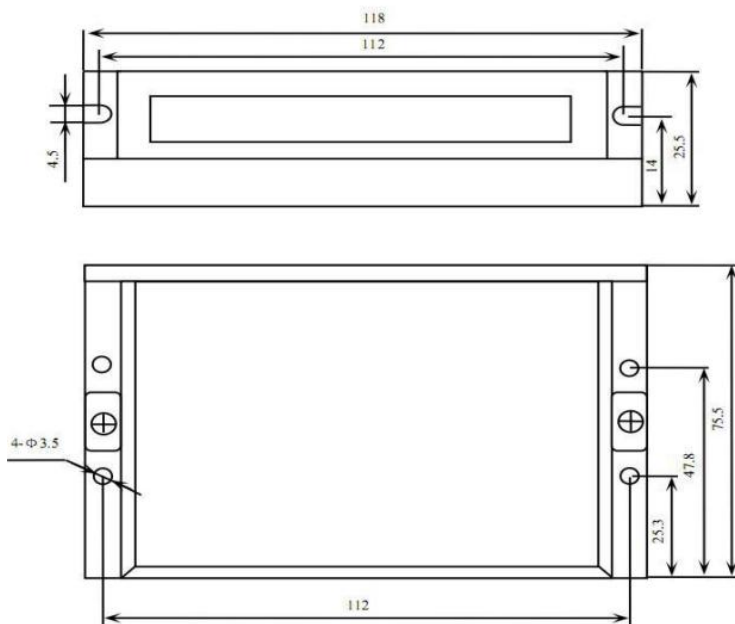

Figure 1 Mechanical specifications

- Side mounting recommended for better heat dissipation

2.4 Elimination of Heat

- DM542T(V4.0) reliable working temperature should be < 40°C (109°F)
- It is recommended to use automatic idle-current mode to reduce motor heating. That means set the SW4 pin of DIP switch at "OFF" position.
- It is recommended to mount the drive vertically to maximize heat sink area. Use forced cooling method to cool if necessary.

3. Connection Pin Assignments and LED Indication

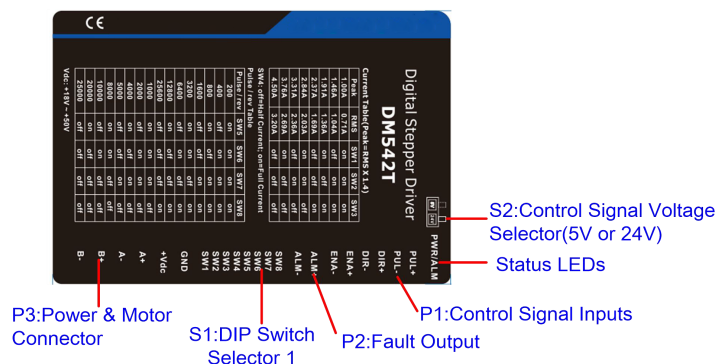

Figure 2 Connectors, DIP switches, and LED locations

The DM542T(V4.0) has three connector blocks P1&P2&P3 (see above picture). P1 is for control signals connections, and P2 is for output signals connections, P3 is for power and motor connections. The following tables are brief descriptions of the three connectors. More detailed descriptions of the pins and related issues are as below.

3.1 P1 - Control Connector

PIN	Details
PUL+	Pulse and Direction Connection: (1) Optically isolated, high level 4.5-5V or 24V, low voltage 0-0.5V (2) Maximum 200 KHz input frequency (3) The width of PUL signal is at least 2.5 μ s, duty cycle is recommended 50% (4) DIR signal requires advance PUL signal minimum 5 μ s in single pulse mode (5) The factory setting of control signal voltage is 24V, must need to set S2 (figure 2) if it is 5V
PUL-	
DIR+	
DIR-	
ENA+	
ENA-	

Notes:

- (1) Shield cables are required for P1;
- (2) Don't tie P1/P2 cables and P3 cables together.

3.2 P2 - Fault Output Connector

Pin	Details
ALM+	(1) Maximum 30V/100mA output (2) Sinking or sourcing (3) The resistance between ALM+ and ALM- is low impedance as default, and will change to high when the drive goes into error protection. (4) Fault connection refer to chapter 4.2
ALM-	

3.3 P3 - Motor and Power Supply Connector

Pin Function	Details
GND	Power supply ground connection.
+Vdc	Power supply positive connection. Suggest 24-48VDC power supply voltage
A+, A-	Motor Phase A connections. Connect motor A+ wire to A+ Pin; motor A- wire to A-
B+, B-	Motor Phase B connections. Connect motor B+ wire to B+ Pin; motor B- wire to B-



Warning: Don't plug or unplug the P1&P2&P3 terminal block to avoid drive damage or injury when DM542T(V4.0) is powered on.

3.4 LED Light Indication

There are two LED lights for DM542T(V4.0). The GREEN one is the power indicator which will be always on generally. The RED one is a protection indicator which will flash 1-2 times in a 3-second period, when protection enabled for a DM542T(V4.0). Different number of flashes indicates different protection type (read section 11 for detail).

4. Control Signal and Output Signal

4.1 Control Signal Connection

The DM542T(V4.0) can accept differential or single-ended control signals (pulse, direction, and enable) in open-collector or PNP connection through the P1 connector (figure 2). It is recommend to add an EMI line filter between the power supply and the drive to increase noise immunity for the drive in interference environments.

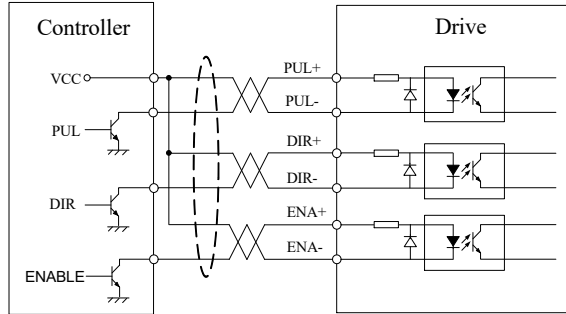

Figure 4: Connections to open-collector signal (common-anode)

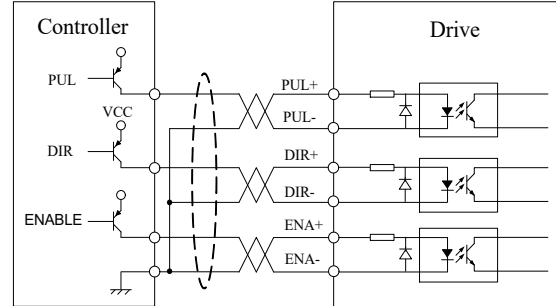

Figure 5: Connections to PNP signal (common-cathode)

Notes:

- (1) ENA signal is no-connected as default;
- (2) Control signal amplitude is 24 V as default. If it is 12 V, please set the S2 (Figure 2) selector switch to 5 V first, then connect 1KΩ resistor; If it is 5V, please set the S2 to 5V.

4.2 Fault Output Connection

When over voltage or over current protection happens, DM542T(V4.0) red status LED light will blink and the impedance state between ALM+ and ALM- will change (from low to high or high to low depending on configuration) and can thus be detected. Fault output connection is optional, and it can be connected either in sinking or sourcing.

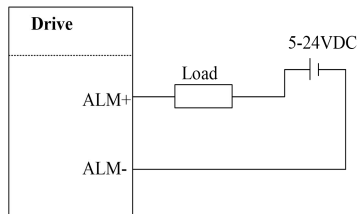

Figure 6 Sinking output

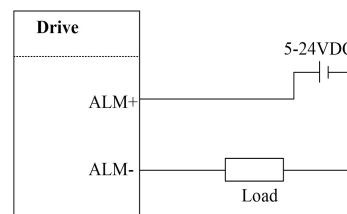

Figure 7 Sourcing output

5. Motor Connection

The DM542T(V4.0) can drive 2-phase and 4-phase bipolar hybrid stepper motors.

The 4 lead motors are the least flexible and easy to connect. The output current from drive that is multiply the specified phase current by 1.4 to determine the peak output current.

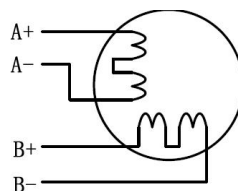

Figure 9: 4-lead Motor Connections

6. Power Supply Selection

The DM542T(V4.0) can power medium and large size stepping motors (frame size from NEMA 11 to 24). To get good driving performances, it is important to select supply voltage and output current properly. Generally speaking, supply voltage determines the high speed performance of the motor, while output current determines the output torque of the driven motor (particularly at lower speed). Higher supply voltage will allow higher motor speed to be achieved, at the price of more noise and heating. If the motion speed requirement is low, it's better to use lower supply voltage to decrease noise, heating and improve reliability.

6.1 Power Supply Sharing

Multiple DM542T(V4.0) drives can share one power supply to reduce cost, if that power supply has enough power capacity. To avoid cross interference, connect each stepper drive directly to the shared power supply separately. To avoid cross interference, DO NOT daisy-chain connect the power supply input pins of the Drivers. Instead connect them to power supply separately.

6.2 Selecting Supply Voltage

The DM542T(V4.0) is designed to operate within 18 - 50VDC voltage input. When selecting a power supply, besides voltage from the power supply power line voltage fluctuation and back EMF voltage generated during motor deceleration needs also to be taken into account. Please make sure leaving enough room for power line voltage fluctuation and back-EMF voltage charge back.

Higher supply voltage can increase motor torque at higher speeds, thus helpful for avoiding losing steps. However, higher voltage may cause bigger motor vibration at lower speed, and it may also cause over-voltage protection or even drive damage. Therefore, it is suggested to choose only sufficiently high supply voltage for intended applications.

7. DIP Switch Configurations

The DM542T(V4.0) has one 8-bit DIP switch and one 1-bit selector. The first 8-bit is used to configure settings of micro step resolution, output current, motor standstill current, pulse type and smoothing time as shown below.

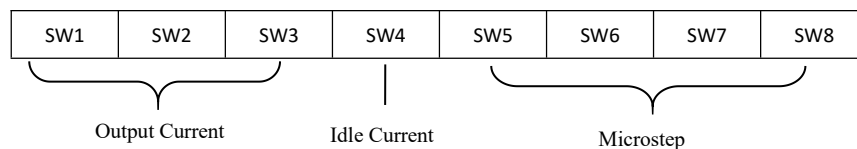

The second 1-bit selector is located on the top (S2 in figure 2), used to configure the voltage of control signals. For the safety of optically coupled, the factory setting is 24V, [which no need to connect 2K resistors like the old drives, making it easier to use.](#) When the voltage of the control signal is 5V, the S2 must be set to 5V, otherwise, the motor won't work.

7.1 Microstep Resolution Configurations

Microstep resolution is set by SW5, 6, 7, 8 of the DIP switches as shown in the following table.

Microstep	Steps/rev.(for 1.8°motor)	SW5	SW6	SW7	SW8
1	200	ON	ON	ON	ON
2	400	OFF	ON	ON	ON
4	800	ON	OFF	ON	ON
8	1600	OFF	OFF	ON	ON
16	3200	ON	ON	OFF	ON
32	6400	OFF	ON	OFF	ON
64	12800	ON	OFF	OFF	ON
128	25600	OFF	OFF	OFF	ON
5	1000	ON	ON	ON	OFF
10	2000	OFF	ON	ON	OFF
20	4000	ON	OFF	ON	OFF
25	5000	OFF	OFF	ON	OFF
40	8000	ON	ON	OFF	OFF
50	10000	OFF	ON	OFF	OFF
100	20000	ON	OFF	OFF	OFF
125	25000	OFF	OFF	OFF	OFF

7.2 Output Current Configurations

For a given motor, higher drive current will make the motor to output more torque, but at the same time causes more heating in the motor and drive. Therefore, output current is generally set to be such that the motor will not overheat for long time operation. Since parallel and serial connections of motor coils will significantly change resulting inductance and resistance, it is therefore important to set drive output current depending on motor phase current, motor leads and connection methods. Phase current rating supplied by motor manufacturer is important in selecting drive current, however the selection also depends on leads and connections.

The first three bits (SW1, 2, 3) of the DIP switch are used to set the dynamic current. Select a setting closest to your motor's required current.

7.2.1 Dynamic Current Configurations

Peak Current	RMS Current	SW1	SW2	SW3
1.00A	0.71A	ON	ON	ON
1.46A	1.04A	OFF	ON	ON
1.91A	1.36A	ON	OFF	ON
2.37A	1.69A	OFF	OFF	ON
2.84A	2.03A	ON	ON	OFF
3.31A	2.36A	OFF	ON	OFF
3.76A	2.69A	ON	OFF	OFF
4.50A	3.20A	OFF	OFF	OFF

7.2.2 Idle Current Configuration

SW4 is used to set motor idle current percentage. At OFF position it means the standstill current is set to be 50% of the selected output current. At ON position it means standstill current is set to be 90%.

The current automatically reduced to 50% of the selected dynamic current 0.4 second after the last pulse.

7.3 Automatic Motor Matching & Self Configuration

When powered on a DM542T(V4.0) will automatically configure itself with the best settings to match the driven stepper motor for optimal performance. No action is needed.

8. Wiring Notes

- In order to improve anti-interference performance of the drive, it is recommended to use twisted pair shield cable.
- To prevent noise incurred in PUL/DIR signal, pulse/direction signal wires and motor wires should not be tied up together. It is better to separate them by at least 10 cm, otherwise the disturbing signals generated by motor will easily disturb pulse direction signals, causing motor position error, system instability and other failures.
- If only one power supply serves multiple DM542T(V4.0) drives, separately connecting the drives to the power supply is recommended instead of daisy-chaining.
- It is prohibited to pull and plug connector P2 while the drive is powered ON, because there is high current flowing through motor coils (even when motor is at standstill). Pulling or plugging connector P2 with power on will cause extremely high back-EMF voltage surge, which may damage the drive.

9. Typical Connection

A complete stepping system should include stepping motor, stepping drive, power supply and controller (pulse generator). A typical connection is shown as below.

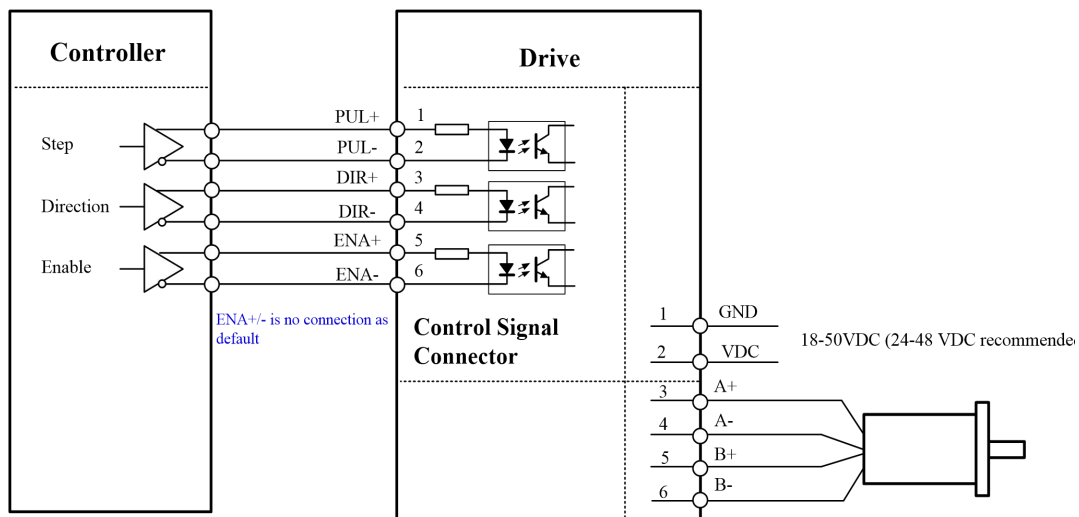

Figure 14: Typical connection

10. Sequence Chart of Control Signals

In order to avoid some fault operations and deviations, PUL, DIR and ENA should abide by some rules, shown as following diagram:

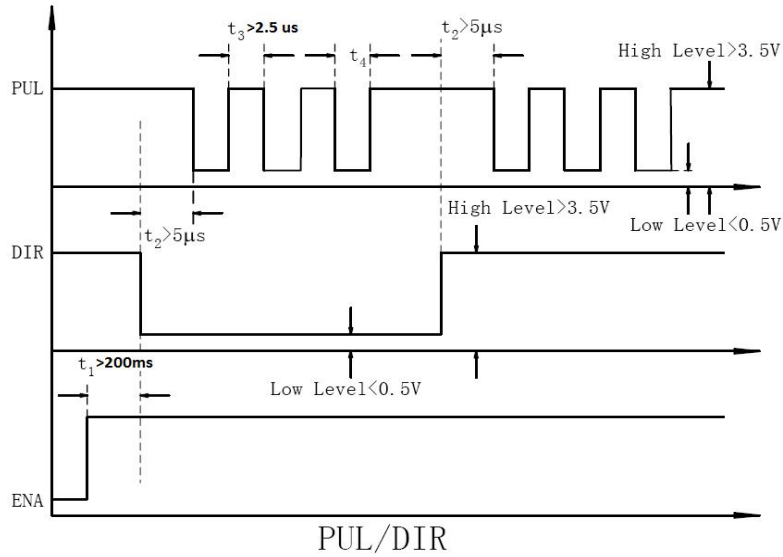

Figure 15: Sequence chart of control signals

Remark:

- t_1 : ENA must be ahead of DIR by at least 200ms. Usually, ENA+ and ENA- are NC (not connected). See “Connector P1 Configurations” for more information.
- t_2 : DIR must be ahead of PUL effective edge by $5\mu\text{s}$ to ensure correct direction;
- t_3 : Pulse width not less than $2.5\mu\text{s}$;
- t_4 : Low level width not less than $2.5\mu\text{s}$;
- Duty cycle of Pulse signal is recommend 50%.

11. Protection Functions

To improve reliability, the drive incorporates some built-in protections features.

Priority	Time(s) of Blink	Sequence wave of red LED	Description
1st	1		Over-current protection activated when peak current exceeds the limit.
2nd	2		Over-voltage protection activated when drive working voltage is greater than 60VDC
3rd	3		Reserved.

When above protections are active, the motor shaft will be free or the red LED blinks. Reset the drive by repowering it to make it function properly after removing above problems.

12. Troubleshooting

In the event that your drive doesn't operate properly, the first step is to identify whether the problem is electrical or mechanical in nature. The next step is to isolate the system component that is causing the problem. As part of this process you may have to disconnect the individual components that make up your system and verify that they operate independently. It is important to document each step in the troubleshooting process. You may need this documentation to refer back to at a later date, and these details will greatly assist our Technical Support staff in determining the problem should you need assistance.

Many of the problems that affect motion control systems can be traced to electrical noise, controller software errors, or mistake in wiring.

Problem Symptoms and Possible Causes

Symptoms	Possible Problems
Motor is not rotating	No power
	Microstep resolution setting is wrong
	DIP switch current setting is wrong
	Fault condition exists
	The drive is disabled
Motor rotates in the wrong direction	Motor phases may be connected in reverse
The drive in fault	DIP switch current setting is wrong
	Something wrong with motor coil
Erratic motor motion	Control signal is too weak
	Control signal is interfered
	Wrong motor connection
	Something wrong with motor coil
	Current setting is too small, losing steps
Motor stalls during acceleration	Current setting is too small
	Motor is undersized for the application
	Acceleration is set too high
	Power supply voltage too low
Excessive motor and drive heating	Inadequate heat sinking / cooling
	Automatic current reduction function not being utilized
	Current is set too high